

### Typical Features

- ◆ Wide input voltage range (1.7 : 1)
- ◆ Efficiency up to 94%
- ◆ Low no-load power consumption
- ◆ Operating temperature from -40°C to +100°C
- ◆ High isolation voltage 4242VDC (input-output) & 2100VDC (input-case)
- ◆ Input under voltage protection, output over voltage, short circuit, over current & over temp. protections
- ◆ Standard full brick size



**ZAD2000-280S48** is a high-performance full brick size DC-DC modular converter with the rated input voltage 280VDC (full range from 250V to 425VDC), regulated single output 48V/2000W without minimum load limit. It has the advantage of high isolation voltage, Max operating temperature up to 100°C, with input under voltage protection, output over current, over voltage, over temperature and short circuit protections, input ON/OFF control, output voltage distal end compensation and output voltage Trim functions, etc.

### Typical Product List

Part No.	Input voltage range (VDC)	Output power (W)	Output voltage (VDC)	Output current (A)	Ripple & Noise (mVp-p)	Full load efficiency (%) Min/Typ.	Remarks
<b>ZAD2000-280S48</b>	<b>250 - 425</b>	<b>2000</b>	<b>48</b>	<b>42</b>	<b>480</b>	<b>92/94</b>	

### Input Specifications

Item	Operating conditions	Min.	Typ.	Max.	Unit
Input current Max	Input voltage 250Vdc, full load output	--	--	10	A
No load input current	Rated input voltage	--	--	50	mA
Inrush voltage (1sec. max.)	The unit could be permanently damaged by the input over this voltage	-0.7	--	450	VDC
Start-up voltage		--	--	250	
Under voltage protection	With half load test	--	--	240	
ON/OFF Control	Apply ≤1.2V or leave it open between ON/OFF+ & ON/OFF- to turn ON the converter Apply 3.5-12V between ON/OFF+ & ON/OFF- to turn OFF the converter				

### Output Specifications

Item	Operating conditions	Min.	Typ.	Max.	Unit
Output voltage		47.5	48.0	48.5	V
Line regulation	Full load, input voltage from low to high	--	±0.2	±0.5	%
Load regulation	Nominal input voltage, 10%-100% load	--	±0.2	±0.5	%
Transient recovery time	25% load step change (step rate 1A/50uS)	--	200	250	uS
Transient response deviation		-5	--	+5	%
Ripple & Noise	20M bandwidth, with external capacitor >1000uF	--	300	480	mVp-p
Output voltage TRIM		-10	--	+10	%

Output voltage distal-end compensation (Sense)		--	--	3	%
Over temperature protection	Maximum temperature of the metal base	100	105	115	°C
Over voltage protection		120	--	130	%
Over current protection		46	--	54	A
Short circuit protection		Output constant current, self-recovery			

**General Specifications**

Item	Operating conditions		Min.	Typ.	Max.	Unit
Isolation voltage	I/P-O/P	Test 1min, leakage current <3mA	4242	--	--	VDC
	I/P-Case	Test 1min, leakage current <3mA	2100	--	--	VDC
	O/P-Case	Test 1min, leakage current <3mA	500	--	--	VDC
Insulation resistance	I/P-O/P	@ 500VDC	100	--	--	MΩ
Switching frequency			--	170	--	KHz
MTBF			150	--	--	K hours

**Environmental characteristics**

Item	Operating conditions		Min.	Typ.	Max.	Unit
Operating temperature	Refer to the temperature derating graph		-40	--	+100	°C
Storage humidity	No condensing		5	--	95	%RH
Storage temperature			-40	--	+125	°C
Pin soldering temperature	1.5mm from the case, soldering time <1.5S		--	--	+350	
Cooling requirement			EN60068-2-1			
Dry heat requirement			EN60068-2-2			
Damp heat requirement			EN60068-2-30			
Shock and Vibration			IEC/EN 61373 C1/Body Mounted Class B			

**EMC Performances**

Item		Standard	Performance/Class	
EMI	CE	GB/T18655 EN55032	Class A	
	RE	GB/T18655 EN55032	Class A	
EMS	ESD	IEC/EN61000-4-2/GB/T 17626.2-2006	Contact ±6KV/Air ±8KV	perf. Criteria A
	RS	IEC/EN61000-4-3/GB/T 17626.3-2006	10V/m	perf. Criteria A
	EFT	IEC/EN61000-4-4/GB/T 17626.4-2008	±2kV 5/50ns 5kHz	perf. Criteria A
	Surge	IEC/EN61000-4-5/GB/T 17626.5-2008	Line to line ±1KV, line to ground ±2KV	perf. Criteria A
	CS	IEC/EN61000-4-6/GB/T 17626.6-2008	0.15MHz-80MHz 10 Vr.m.s	perf. Criteria A

**Physical Characteristics**

Case Materials	Metal base + plastic case in black, flame class UL94-V0
Cooling Method	Conduction cooling or forced air cooling with fan
Unit Weight	235g

**Mechanical Dimensions and Pin-out Function Description**

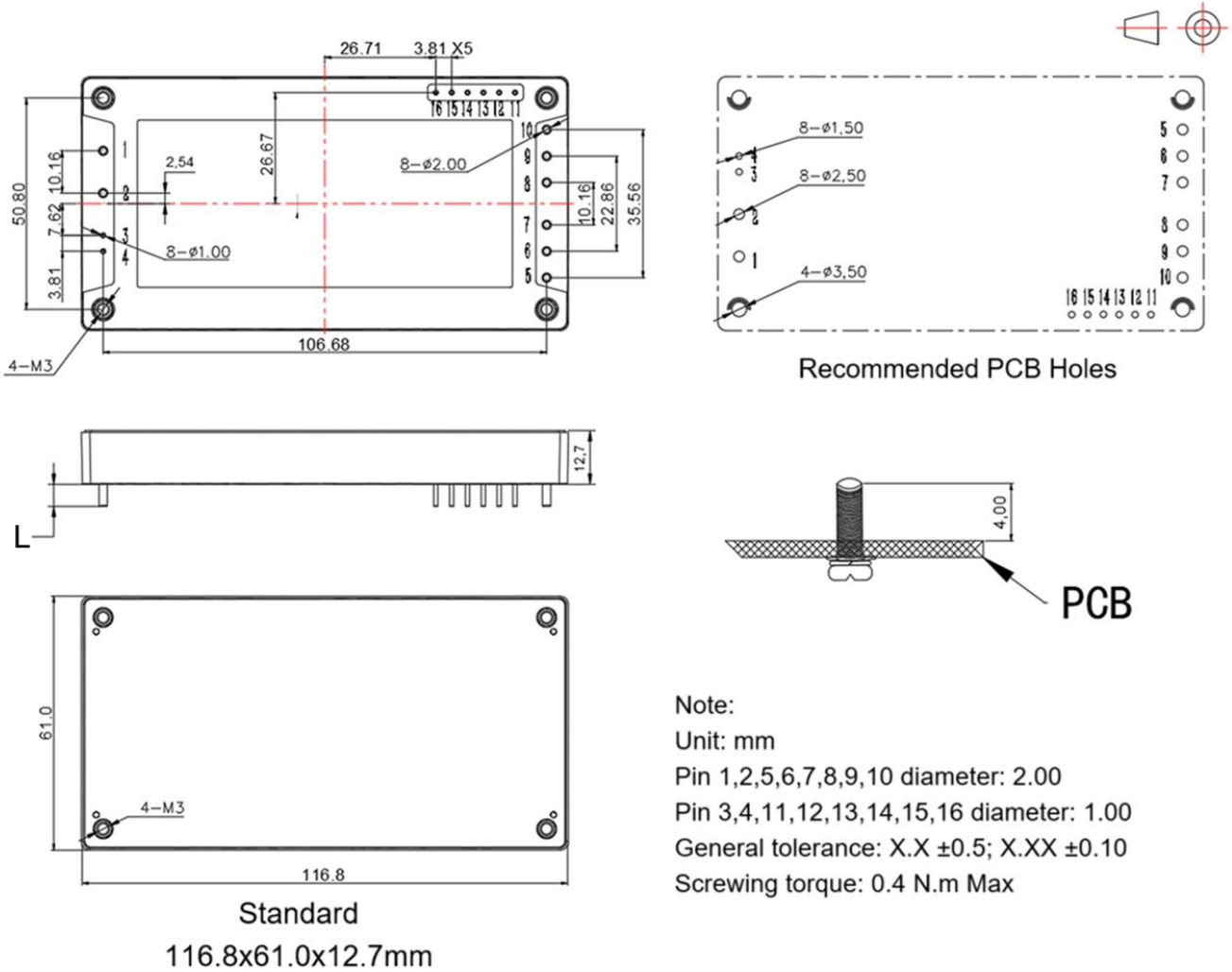

**Pin Length L=5.3mm**

<b>Pin No.</b>	<b>1</b>	<b>2</b>	<b>3</b>	<b>4</b>	<b>5</b>	<b>6</b>	<b>7</b>	<b>8</b>
Function	Vin-	Vin+	ON/OFF-	ON/OFF+	Vout+	Vout+	Vout+	Vout-
Description	Input V-	Input V+	ON/OFF Control	ON/OFF Control	Output V+	Output V+	Output V+	Output V-
<b>Pin No.</b>	<b>9</b>	<b>10</b>	<b>11</b>	<b>12</b>	<b>13</b>	<b>14</b>	<b>15</b>	<b>16</b>
Function	Vout-	Vout-	-Sense	+Sense	TRIM	PC	IOG	AUX
Description	Output V-	Output V-	Output distal end compensation S-	Output distal end compensation S+	Output Voltage Trim	Current share bus	Output Status	Aux-power supply

Note:

- 1.IOG is the output status signal, it is at low impedance while the converter is operating normally, it is at high impedance while the converter is operating under the abnormal condition, the maximum current 10mA.
2. AUX is the auxiliary power supply, the voltage is 14V at normal operation, the maximum overcurrent is 20mA.

### Product Characteristics Graphs

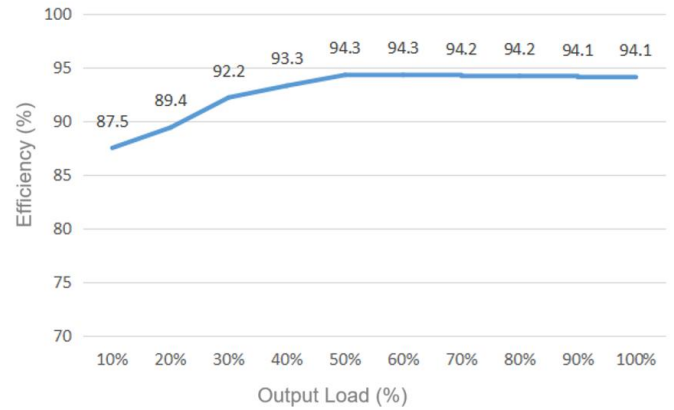
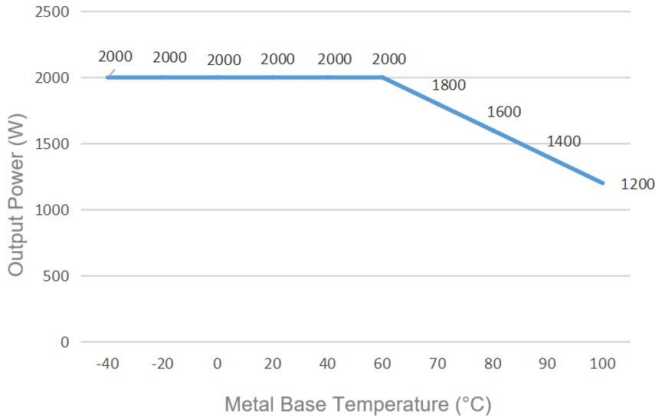

**Note:**

- The output power and the efficiency in the graphs are tested with the typical values.
- The data in the temperature derating graph is tested at Aipu laboratory test conditions. It is recommended to keep the temperature of the metal base not more than 60 °C when the converter operates at the rated load for the application.

### Recommended circuits for application

#### 1. Typical application circuit diagram

If this circuit diagram recommended below is not adopted, please use an electrolytic capacitor  $\geq 100 \mu\text{F}$  at the input to suppress the possible surge voltage.

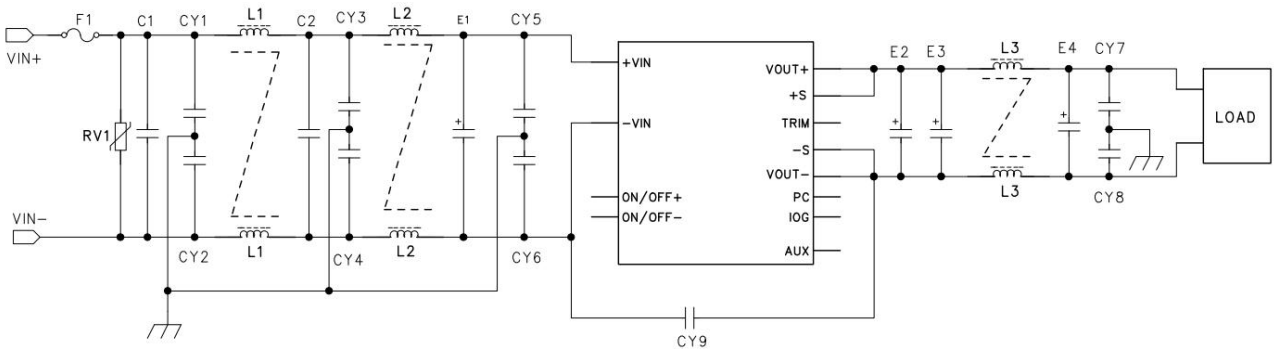

F1	T15A/250Vac, Time-delay fuse
RV1	14D 520V Varistor
C1, C2	105/630V Polyester Film Capacitor
CY1, CY2, CY3, CY4, CY5, CY6	102/250Vac Y2 capacitor
CY7, CY8	103/2KV Ceramic Capacitor
CY9	102/250Vac Y1 capacitor
E1	100 $\mu\text{F}$ /450V Electrolytic Capacitor
E2, E3	1500 $\mu\text{F}$ /63V Electrolytic Capacitor (More than one connected in parallel is acceptable)
L1, L2	>5mH, temperature rise less than 25°@10A
L3	>220uH, temperature rise less than 25°@42A

#### 2. ON/OFF control circuit & application instruction

- ON/OFF control internal circuit diagram shown on the right
- Apply  $\leq 1.2\text{V}$  or leave it open between ON/OFF+ & ON/OFF- to turn ON the converter
- Apply 3.5-12V between ON/OFF+ & ON/OFF- to turn OFF the converter

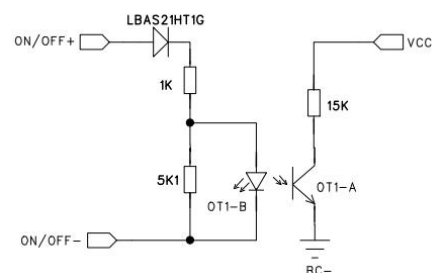

**3. Output voltage TRIM application**

The Trim function adjusts the output voltage by an external Trim resistor.

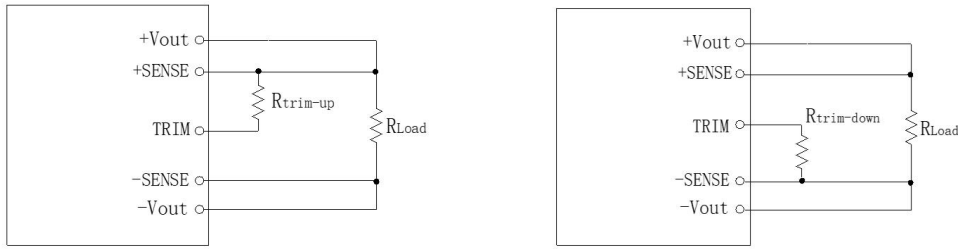

The output voltage can be adjusted between 90% and 110% of Vo by an external resistor used between the terminals of TRIM and Vo. The voltage can be increased by the resistor between TRIM and Vo+, and it can be decreased by the resistor between TRIM and Vo-. The resistor should be placed as closely as possible to the converter terminals. TRIM terminal should be No Connection when TRIM is not needed. The resistances of Trim-up and Trim-down calculating formulars are shown below.

$$R_{trim-up} = (5.1 * \Delta * V_o - 12.75) / (2.5 * \Delta - 2.5) - 10.2 \text{ (K}\Omega\text{)}$$

$$R_{trim-down} = (10.2 * \Delta - 5.1) / (1 - \Delta) \text{ (K}\Omega\text{)}$$

For example, Vo=48V, we need increase it to be 52.8V,  $\Delta = 52.8/48 = 1.1$ ,  $R_{trim-up} = (5.1 * 1.1 * 48 - 12.75) / (2.5 * 1.1 - 2.5) - 10.2 = 1015.92K\Omega$ ; If we need decrease the voltage to be 43.2V,  $\Delta = 43.2/48 = 0.9$ ,  $R_{trim-down} = (10.2 * 0.9 - 5.1) / (1 - 0.9) = 40.8K\Omega$

**4. Application for the converters parallel operation to increase the output power**

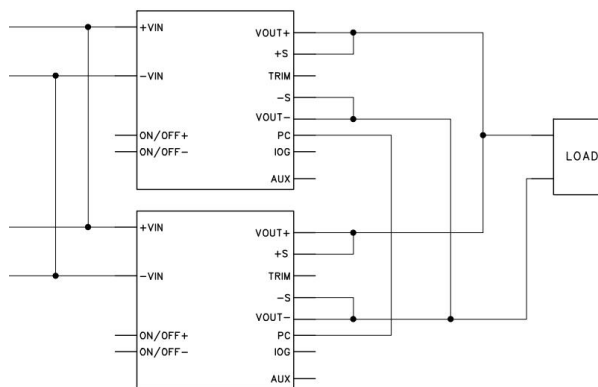

**Application circuit diagram for converters connected in parallel (≥2 converters)**

Requirements:

- 1) Input connected in parallel
- 2) Current share bus PC terminals connected in parallel
- 3) Output connected in parallel
- 4) External application circuit refers to the single unit application

**Others**

1. The product warranty period is two years. The failed product can be repaired/replaced free of charge if it operates at normal condition. A paid service shall be also provided if the product fails after operating under wrong or unreasonable conditions.
2. Aipupower can provide customization design and filter modules for matching, please contact our technician for details.

**Guangzhou Aipu Electron Technology Co., Ltd**

Address: Building 4, HEDY Park, No.63, Punan Road, Huangpu Dist, Guangzhou, China.

Tel: 86-20-84206763 Fax: 86-20-84206762 HOTLINE: 400-889-8821

E-mail: [sales@aipu-elec.com](mailto:sales@aipu-elec.com) Website: [www.aipupower.com](http://www.aipupower.com)